

Design and development of RFID based smart shopping cart using Arduino

Peeyush Garg

peeyush.garg@jaipur.manipal.edu

Tanvi Joshi

tanviakjoshi1210@gmail.com

Deepika Bansal

deepika.bansal@jaipur.manipal.edu

ABSTRACT

In the present era of socio-economic development, technologies have been contributing not only for improving supply chain management, but also to enhance customer facilities and satisfactions. Now a days, shopping centers and city malls are the prime requirement of society, where customers get freedom to see, choose and collect items as per their requirements and convenience. These stores and malls are situated in metropolitan cities and easily approachable, which increases the rush at these places with a high rate, tends to long queue at billing counters. It also needs skilled workers to arrange items in shopping center, also guide about the shopping items to customers as well as at billing counter. The proposed system is a smart shopping cart, comprises RFID reader and on-board buttons as inputs, microcontroller-based Arduino board as data acquisition and control unit, and LCD display is as output unit. The smart cart detects items, then avails option to customer to add new shopping items in bill as well as remove already added items directly from bill. It also sends the final billing information to central server using Wi-Fi module. The developed flexible shopping system provides better informative system along with facility of automatic billing generation and record the information centrally. It also provides better functionality of shopping center, minimize requirement, and working load on shopping center employees.

Keywords: Shopping cart, Arduino Nano, RFID, LCD Panel, Wi-Fi Module.

1. INTRODUCTION

In present scenario, technology have been progressing in various fields such as smart systems, Internet of things, automation, machine learning, crypto currency, supply chain management, to support the social development and fast-growing economy. With the changing time, our requirements are also evolving and increasing, and to fulfil the needs the numbers of shopping centers and city malls have been increasing year by year. Nowadays, shopping centers and city mall have become the essential services of society. The general need of human being involves

a large variety of goods/items, which can be easily available at shopping center under a roof. The proper segregation and well-arrangement of items makes shopping center as a perfect choice for shopping over conventional shopping methods. Also, these stores and malls are easily approachable. So, people usually prefer these shopping centers and malls for shopping, tend to make these places crowded most of the times [1, 2].

A fraction of major shoppers buys more groceries and products than other stuff and sometimes they go over the budget. According to a survey, when the shoppers know exactly what they spent, they are more likely to leave the store with satisfaction [3]. The prime focus of this project is to reduce problems like long queue waiting for billing, especially in India where festival and wedding seasons bring a whole lot of crowds for shopping [4].

The efficient management of these shopping centers and malls, need skilled salespersons to efficiently arrange items, guide customer time to time, and specifically at billing counter. The over-crowd queue at billing counter during rush hours become a noticeable problem in most of the shopping malls, which basically reduce the efficiency of shopping malls in terms of facility provided and number of customers served.

The developed system is one that encourages luxury, accessibility, and effectiveness in social life, which basically use the idea of smart Shopping and smart billing. The system designed is easy to use, efficient, size effective and is low at cost. It provides better shopping experience to customers. Also, more customers can be served in same time subsequently benefiting the retailers and customers, tend to improve performance and management of shopping centers and malls.

This proposed work is essentially an embedded system, comprises a microcontroller board, with RFID reader, input buttons and LCD display panel. The whole assembly is installed on shopping cart. The RFID readers can detect the tag, already attached with shopping items, and provides the information to user on LCD panel. The input buttons provide a way to add as well as remove the items in shopping list, and further for billing. So overall, shopping cart displays list of chosen items on the LCD display, which helps them with their budget section also reduces the shopping duration and helps avoid long queue waiting at the billing counters.

2. LITERATURE REVIEW

Most of existing shopping centers have been using barcode-based scanning of product at billing counter, which improve the identification process of products available and improve the functionality of shopping centers with reduced number of workers [5]. Nowadays, these barcode-based billing counters are having long queue due to long bill preparation time and heavy rush on shopping centers specially during peak hours [6].

Many researchers have addressed problems of long queue of shopping malls and worked for improved method of shopping. Few Researchers compared the different existing technologies used for shopping cart automation like Barcode systems, ZigBee, RFID system; and developed an android app-based shopping system, comprised the

Arduino Uno & Bluetooth module in already published research work [7]. In this, system required a proper cart- mobile Bluetooth in-range connection & a dedicated app designed for adding & removing of items in shopping bill and for processing final bill, also good internet connectivity for customer mobile and shopping mall server. Failing any of these at any instant, may disturbs or stops the functioning of shopping cart system. Sometimes, it is difficult to be ensure good Bluetooth & internet connectivity of mobile with shopping cart and web server respectively [7, 8]. Many researchers were used costlier and complex controller board, which included Raspberry Pi, Arm processors, Zigbee, also add-on circuitry, which makes the system more complex to design and costlier [9-12].

Now, availability of tiny controller board with sufficient numbers of input/output, motivate to develop proposed system, so presented system is small in size, simple in design, easy to programming and comparative cheaper due to proper selection of microcontroller, with an add on feature of IoT based centrally record unit [13].

The presented system is used Arduino Nano controller board and RFID tag-reader. Arduino boards are versatile controller used in varieties of application such as home automation, data loggers, energy managements, robotics etc. [14].

Arduino Nano is cheaper, smaller, and better processor. RFID reader is a gadget which is gathers data from an RFID tag by tracking individual objects. These RFID based systems has a variety of applications which includes smart billing cart, attendance tracking, materials management, in libraries RFID tags are used in books and other materials to track circulation and inventory etc. [15-16].

The presented work also provides a facility to better shopping experience with display the product cost on LCD panel before adding in cart and provision of confirm button on front panel. It also facilitates the customers, to remove any already added product by pressing a button on shopping cart board.

3. FRONT PANEL

The designed system is assembled on shopping cart and the front panel of the designed system comprises product tag reader, display unit and three push buttons as shown in Figure 1. The interactive front panel opens the options to customer to purchase items with ease and flexibility. The customer can check the product information viz. name, specification, and price before purchasing it on LCD display. It also provides the options to remove already added items from the smart shopping cart.

The main control unit of designed system is microcontroller-based control system, which is further circuited with three push buttons, ON/OFF switch, RFID reader and display panel, as shown in the systematic block diagram of designed shopping cart, represented by Figure 2.

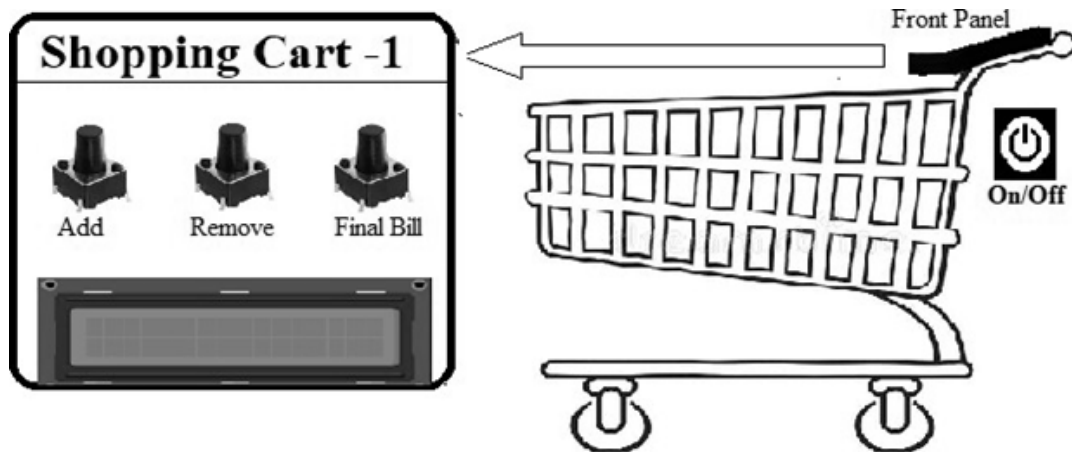

Figure 1. Front panel of proposed system on shopping cart

4. FUNCTIONALITY

The designed system is integrated with RFID reader and a provision of barcode tag to scan the product initially. The process starts with the scanning of the RFID tag, attached with a product. When the customer places the product near scanning area of front panel, the RFID reader RC522 scans the tag and detects the unique identity numbers to respective product and send the information to microcontroller. Meanwhile, the product name and cost are displayed to customer on LCD screen of front panel. This provides a flexibility to customer to decide whether product is suitable to purchase or not. The three push buttons are available on front panel, two of them are to add and remove the scanned product, and third one for final bill preparation.

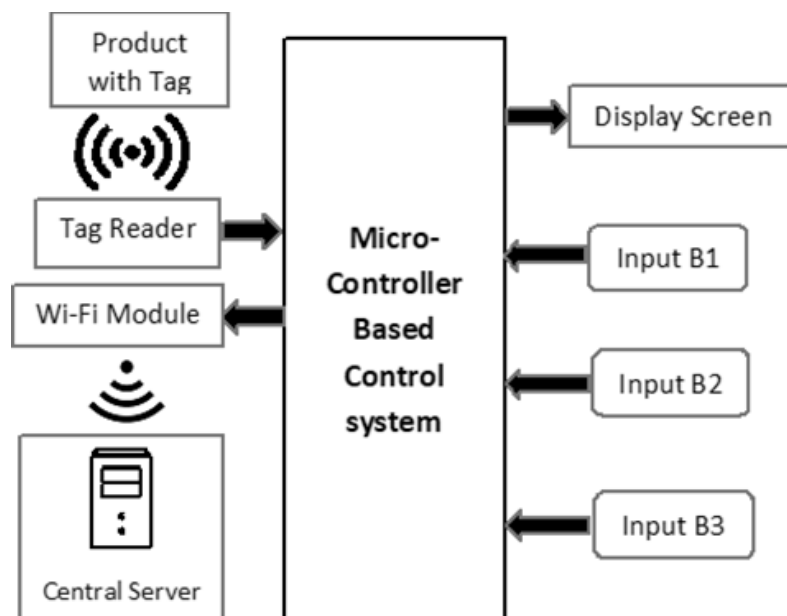

Figure 2. Systematic block diagram of designed smart shopping cart

The first push button 'Add' is circuited with the proposed model which confirms the product into cart by just one press. Further, the desired number of products are added to the cart with same procedure. In case of removal of any product from the cart, the same tag of the product is re-scanned by the RFID reader RC522, connected with the circuit

when being pulled out of the cart. The confirmation of the removal is then made using the second push button 'Remove' circuited with the model. Once all the required items/products are added to the cart, then the third push button 'Final Bill' is used for final bill generation, means total number of products purchased & total billing cost display on LCD screen. Meanwhile, IoT based system is sent the billing information to central unit of shopping center for confirmation and record purpose. After that, customer can approach to out gate for bill payment, and for generation of out-pass without any hassle.

The overall functionality of designed smart shopping diagram is mentioned by flow-chart as presented in Figure 3.

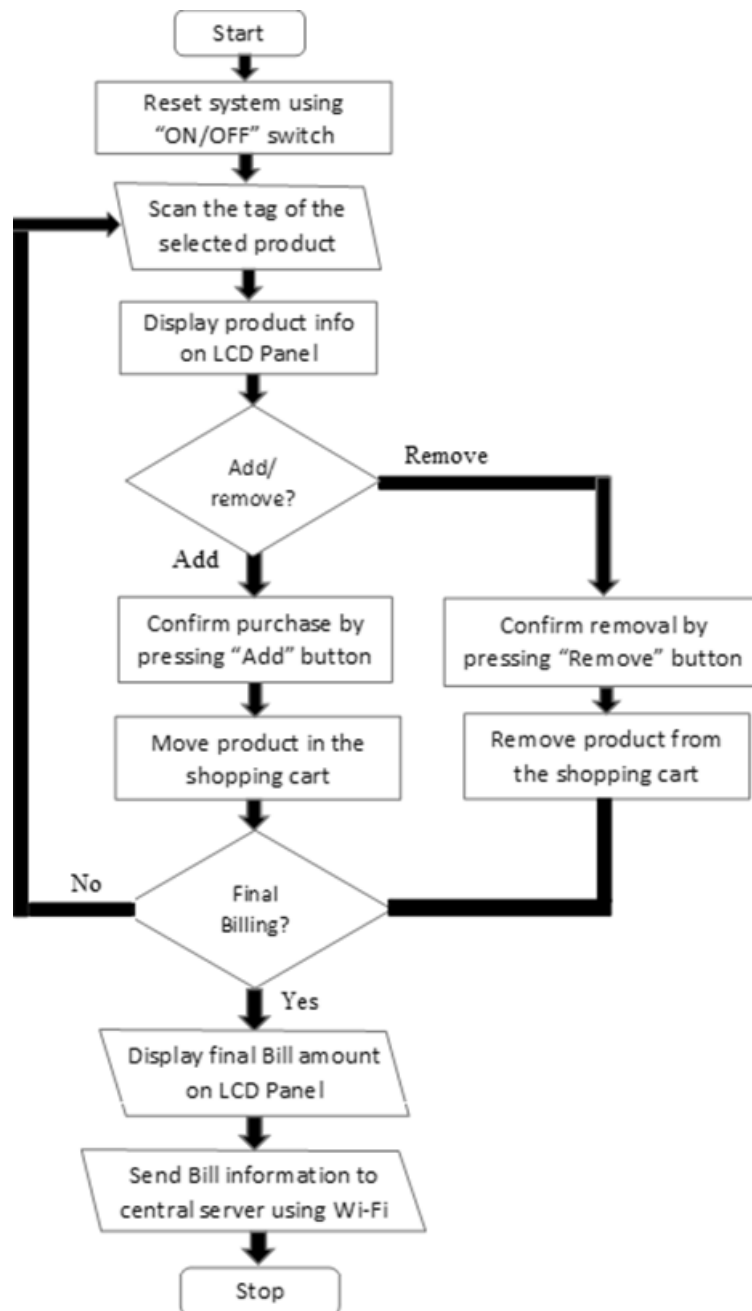

Figure 3. Systematic Flow-chart of designed shopping cart

5. COMPONENT'S SPECIFICATIONS

The major components of the designed smart shopping cart system are Arduino Nano board, RFID reader, ESP8266 WIFI module, LCD display panel.

5.1 Arduino Nano

The microcontroller board Arduino Nano, a breadboard friendly, small, complete board based on the ATmega328. It does not have a DC power jack, hence generally supplied by a B-type micro-USB cable or a 9V battery. It consists of 30 male Input/Output headers, is programmed using the Arduino Software integrated development environment (IDE) [17] and is common to all Arduino boards. In order to communicate with the computer or any other microcontroller a number of facilities are provided by Arduino Nano [6].

The ATmega328 provides UART (5V) serial communication using RX and Tx Pins. The LEDs circuited with the RX and TX pins flashes when data is being transported via USB connection and the FTDI chip to PC [11, 17]. The general pin diagram of Arduino Nano is given in Figure 4.

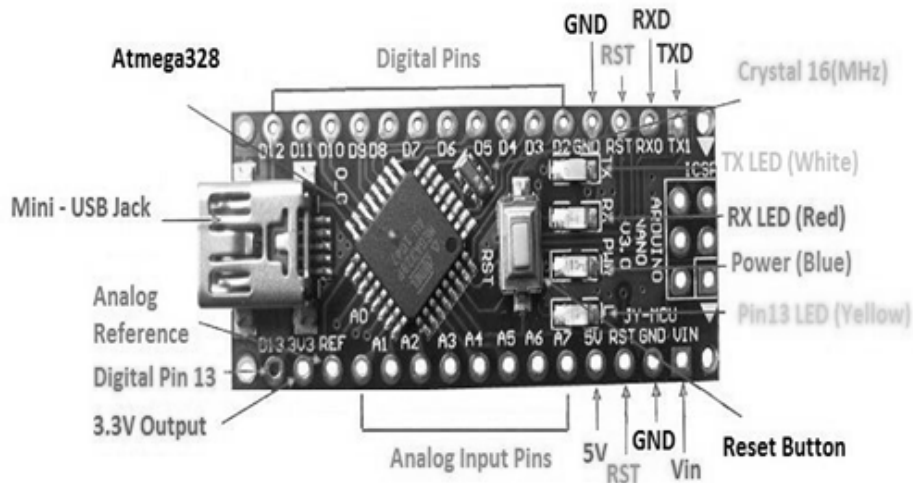

Figure 4. Microcontroller Arduino Nano ATmega328

5.2 RFID Reader

This is a 13.56MHz RF reader cum writer, MFRC522, as shown in Figure 5. It is a transmission chipset which is made and used for contact-less communication having an outstanding demodulation and modulation algorithm for serving uncomplicated 'RF communication at 13.56 MHz'. It uses SPI to connect with various controllers. The basic working principle of this module is that it creates an electromagnetic field of 13.56 MHz that is used to communicate with the RFID tags (ISO 14443A standard tags). Its low voltage, cheap, small and terminal design of the card favorable for modern appliances development and fabrication requirement and makes it ideal for user equipment development [6].



Figure 5. MFRC522 Board [15]

5.3 ESP8266 Wi-Fi Module

ESP8266 is a cheaper system on chip (SoC), which has an integrated TCP/IP protocol stack which gives controller access to the personal Wi-Fi network. This can host an application using not only local Wi-Fi network, but also wireless web server.

The systematic diagram of ESP8266 Wi-Fi module is shown in Figure 6. These Wi-Fi modules are pre-programmed with an AT command set firmware i.e., one can simply connect it with their Arduino device. The on-board processing is powerful enough and allows it to be integrated with the sensors and other application specific devices [18].

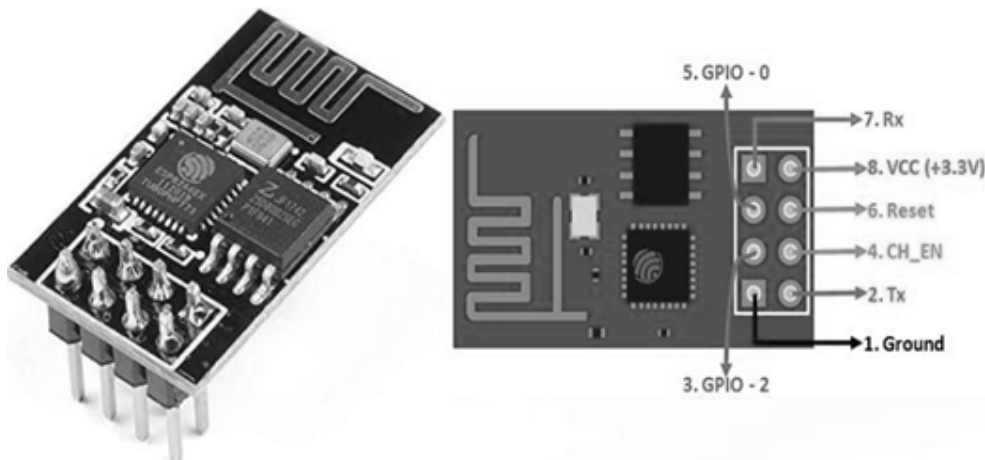

Figure 6. ESP8266 Wi-Fi Module

6. IMPLEMENTATION

Figure 7 shows the systematic circuit diagram of smart shopping cart. The power is supplied to the main unit microcontroller Arduino Nano board using USB power supply. Three push buttons B1, B2 and B3 are connected to Arduino Nano pins D8, D5 and D2 respectively.

The RFID reader RC522 pin SDA is connected to digital pin D10, SCK pin is connected to digital pin D13, the pin MOSI is connected to digital pin-11 of Nano board. The MISO pin of RC522 is connected to digital pin-12 digital pin. Pins GND, RST and VCC are

connected to pins ground, reset, 3V3 of Arduino Nano board, respectively. The LCD display 16x2 pins VSS and R/W are connected to ground and the VDD pin is connected to the power supply. The 10K Ω potentiometer for contrast control is connected to VEE pin. The digital pins D4, D5, D6, D7 of LCD panel are circuited with digital pins D5, D4, D3 and D2 of the controller Nano respectively. The reset and enable of LCD are attached to the digital pins D7 and D6 of the Nano board, respectively.

The Wi-Fi module ESP8266 connected with the circuit had 8 pins in circuit diagram. Ground, CH-EN, GPIO and VCC of ESP8266 are connected to ground, D11, D10 and 3V3 of Arduino board. The Arduino code is written on Arduino IDE software

[19] as per the functionality mentioned in flowchart, which further debug, verify and upload on controller board via COM port. The three push buttons B1, B2, and B3 has specific function 'Add', 'Remove', and 'Final Bill' respectively.

7. DEMONSTRATION & ANALYSIS

A hardware module is implemented for smart shopping cart, which is further tested and summaries below. The designed model is also devised to detects multiple items for testing purpose. The designed model is tested for these items repetitively and random manner. Each time, it produces the accurate detection of item within a second without any noticeable delay.

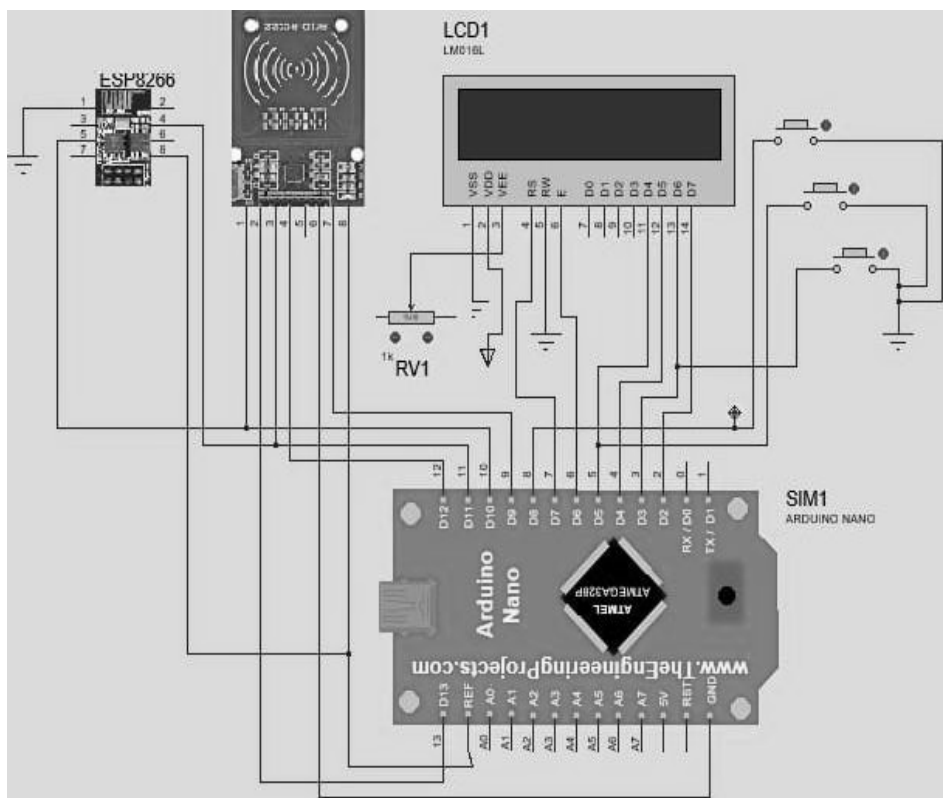

Figure 7. Schematic circuit diagram of designed smart shopping cart

Each item comprises a RFID tag attached to it. Each individual RFID tag is having a 32 bits long unique identity number, so this system can be able to detect more than thousands of items with efficient manner without any false detection.

For the analysis purpose, two products with RFID tag are used named 'ITEM 1' and 'ITEM 2'. Initially, when the system is powered, an initialization text 'Place the Card' is displayed on the LCD screen as shown in Figure 8. This text means that the proposed system is ready to scan the products. Now the shopper can start putting items into the cart. The power button is only accessed by the shopping center crew, not with the customer.

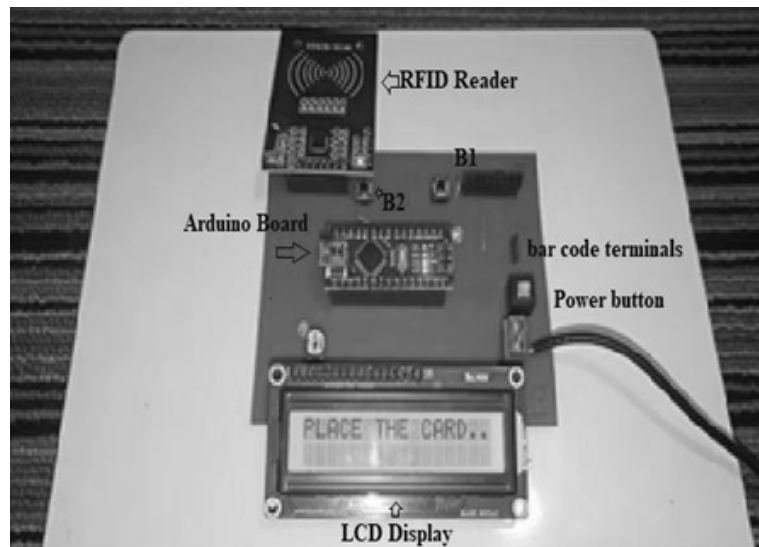

Figure 8. Text displaying when the system is powered and initialized

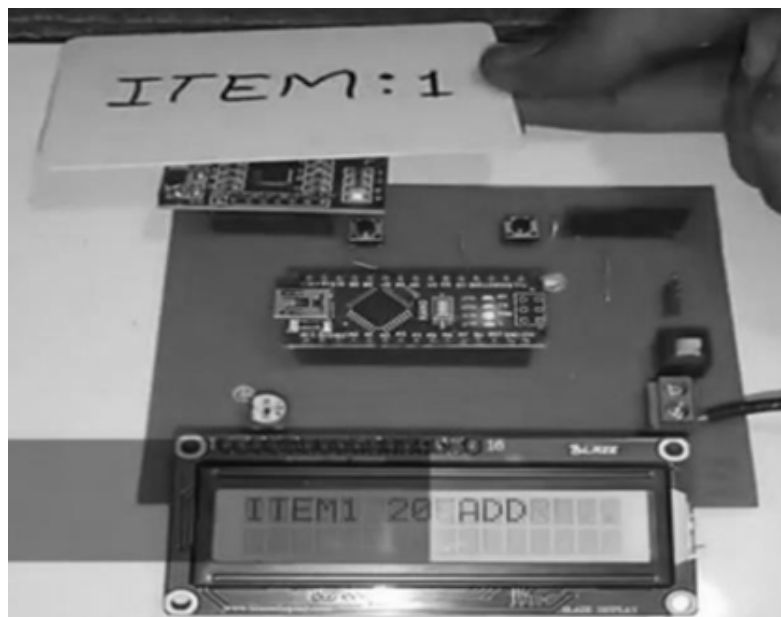

Figure 9. Product details (price) being displayed on LCD

The RFID reader of the cart can detect the tag or items in range of 5cm. As the customer starts putting item-1 on the cart and the product tag is scanned, the product name 'ITEM 1' and its price details will be displayed on the LCD panel for the user as shown in Figure 9. Once, the 'Add' button of front panel is pressed by customer to confirm purchase, then the item 1 is added, and total bill is shown on LCD panel.

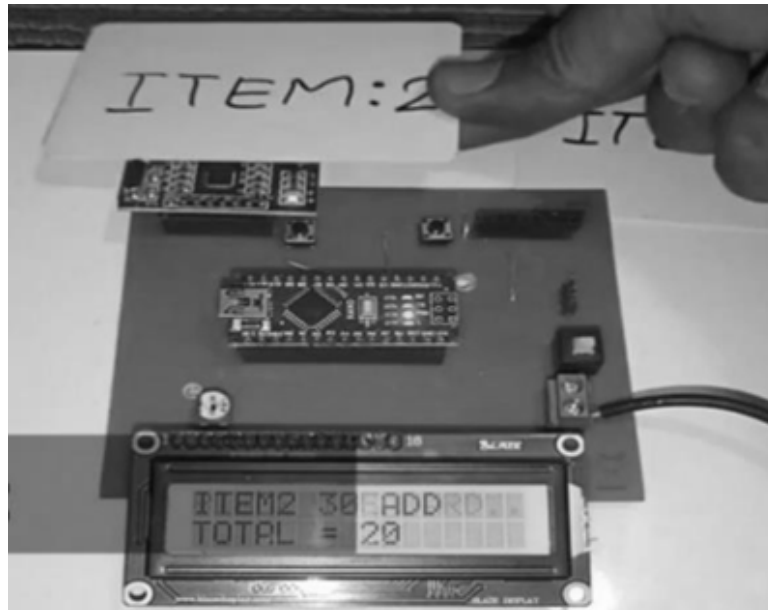

Figure 10. Sum of 2 items being displayed on LCD

Similarly, the next item is put into the shopping cart, the item-2 details and total bill amount is shown on LCD panel as depicted in Figure 10.

If the scanned tag of the product does not match with the crosscheck list of the shopping mall, then the LCD will display 'Not in Menu' and the rest of the final bill is kept displayed as shown in Figure 11.

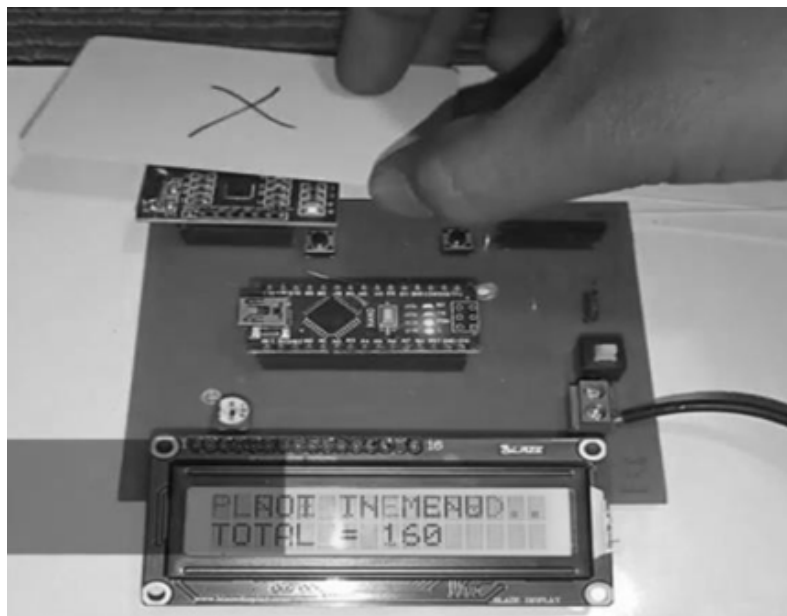

Figure 11. If the item is not in the crosscheck list

In case the customer wants to remove any item from the cart then the tag needs to be re-scanned using the RFID reader and the LCD will display item name along with the price 'ITEM 1 REMOVE' as displayed in Figure 12. Once, the customer confirms removal by pressing 'Remove' push button, then the final bill amount is updated and shown to customer.

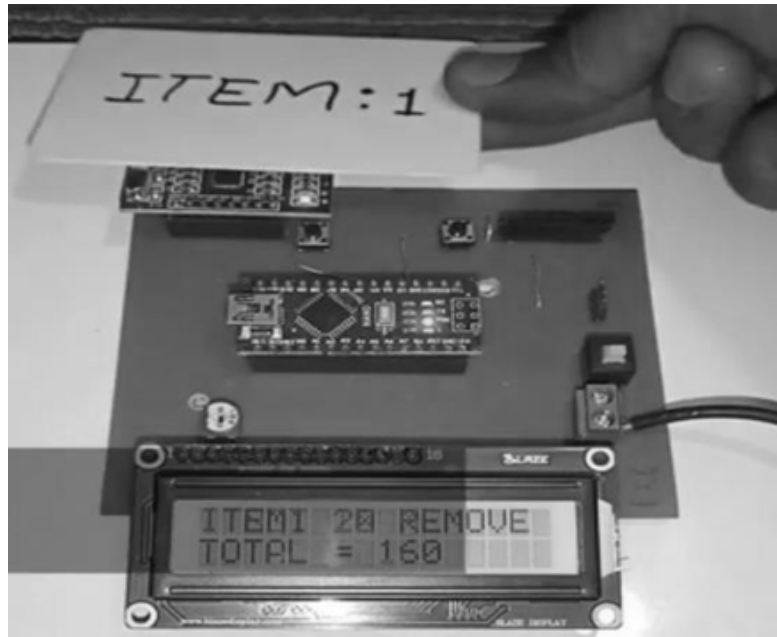

Figure 12. Removal of item 1 being displayed on LCD

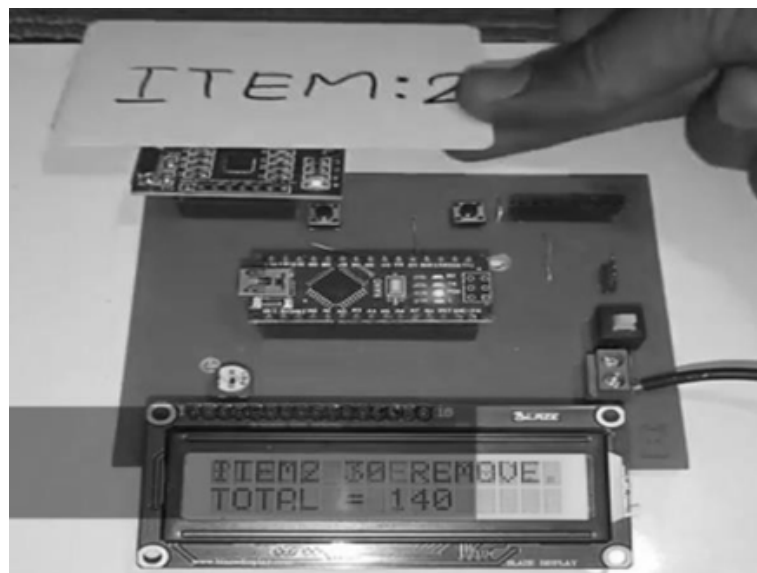

Figure 13. Removal of item 2 being displayed on LCD

Again, if the customer wishes to remove another product 'item 2' from the cart, then it is scanned on front panel. Hereafter, details of the removed item is displayed on the LCD screen 'ITEM 2 REMOVE' along with the total bill including the previously removed item as depicted in Figure 13.

When the shopping is completed and if the shopper wishes to finalize the cart bill, then a total bill is flashed on the LCD panel after pressing 'Final Bill' push button. The LCD screen displays the final bill amount, the amount balance after final addition and reduction of the items in the cart. The final billing information is transferred to central server using ESP8266 WIFI module for record keeping and for further payment and out pass generation.

The user puts the item in shopping cart after scanning at front panel and confirm the purchase by pressing a 'add' button. The total number of items, displayed during final

bill generation is checked with items at exit gate. So, product, not included in bill can be identified & removed.

8. Conclusion

This designed model of Smart Shopping Trolley helps customers in shopping and managing bill within the budget of the customer. Also, users become aware of the total bill amount during the purchasing time and hence prevents them from over-shopping, reduce shopping time and enhances the better shopping experiences of customers in supermarkets.

The designed model is provided the flexibility to add or remove items at any time, before producing the final bill. It also provides the sufficient information about product while adding in cart. The user-friendly front panel of developed system provides convenient, satisfactory, and very flexible shopping experiences to customer with unique features of 'Add', 'Remove' and 'Final bill' buttons & LCD display.

The practical feasibility of the system is tested for addition and removal of two items, further the generation of final bill. The system can be expanded with the providing information in database of thousands of items. After that, the system is ready to facilitate a big shopping mall.

It also reduces the expenses that are incurred by the management. The employees working at the billing counter at the supermarket gets benefited with respect to the time saving factor and least manpower. These smart shopping trolleys can be used in all kinds of retail shopping malls, grocery stores, clothing showrooms and supermarkets.

9. REFERENCES

- [1] A. Tandon, A. Gupta, and V. Tripathi, "Managing shopping experience through mall attractiveness dimensions," *Asia Pacific J. Mark. Logist.*, Vol. 28, No. 4, pp. 634–649, Jan. 2016.
- [2] K. Still, M. Papalexi, Y. Fan, and D. Bamford, "Place crowd safety, crowd science? Case studies and application", *Journal of Place Management and Development*, Vol. 13 No. 4, pp. 385-407, 2020, <https://doi.org/10.1108/JPM-10-2019-0090>
- [3] R. Chatterjee and Y. S. Shukla, "Examining the role of culture, retail environment, and emotions in determining festival shopping engagement: an emerging market perspective," *Int. J. Indian Cult. Bus. Manag.*, Vol. 20, No. 3, pp. 385–408, 2020.
- [4] T. Sethjinda and S. Kitwimontrakul, "The influence of smartwatch attributes towards users purchase intentions in the Bangkok metropolitan area.," *Walailak J. Sci. Technol.*, Vol. 18, No. 2, 2021.
- [5] E. Basker, "Raising the barcode scanner: Technology and productivity in the retail sector," *Am. Econ. J. Appl. Econ.*, vol. 4, no. 3, pp. 1–27, 2012.
- [6] M. R. Mane, N. G. Aman, S. D. Patil, and A. L. Lakesar, "Electronic shopping using barcode scanner," *Int. Res. J. Eng. Technol.*, Vol. 3, No. 04, 2016.

- [7] M. Shahroz, M. F. Mushtaq, M. Ahmad, S. Ullah, A. Mehmood and G. S. Choi, "IoT-Based Smart shopping cart using radio frequency identification," in *IEEE Access*, Vol. 8, pp. 68426- 68438, 2020, doi: 10.1109/ACCESS.2020.2986681.
- [8] S. K. Shankar, S. Balasubramani, S. A. Basha, S. Ariz Ahamed and N. S. Kumar Reddy, "Smart trolley for smart shopping with an advance billing system using IoT," 2021 5th International Conference on Computing Methodologies and Communication (ICCMC), 2021, pp. 390-394, doi: 10.1109/ICCMC51019.2021.9418348.
- [9] T. R. Lekhaa, S. Rajeshwari, J. A. Sequeira, and S. Akshayaa, "Intelligent shopping cart using bolt esp8266 based on internet of things," 2019 5th Int. Conf. Adv. Comput. Commun. Syst. (ICACCS), 2019, pp. 758–761, doi: 10.1109/ICACCS.2019.8728346.
- [10] T. K. Meghana, "Smart shopping cart with automated billing system" *International Journal of Engineering Research & Technology*, Vol. 8, no.11, pp. 88–91, 2020.
- [11] S. Mekruksavanich, "The smart shopping basket based on IoT applications," *Proc. IEEE Int. Conf. Softw. Eng. Serv. Sci. (ICSESS)*, 2019, pp. 714–717, doi: 10.1109/ICSESS47205.2019.9040750.
- [12] P. Chandrasekar and T. Sangeetha, "Smart shopping cart with automatic billing system through RFID and ZigBee," 2014 Int. Conf. Inf. Commun. Embed. Syst. (ICICES), 2014, pp. 1–4, doi: 10.1109/ICICES.2014.7033996.
- [13] P. Garg, S. Agrawal, W Yiyang, A Saraswat, "Design and implementation of interactive home automation system using LabVIEW", *Proceedings of First International Conference on Smart System, Innovations and Computing*, 2018, Vol. 79, pp 371-381, doi:10.1007/978-981-10-5828-8-36.
- [14] M. Schwartz, "Internet of things with arduino cookbook" Packt Publishing Ltd, 2016.
- [15] B. M. Stephen, E S Sanjay, R. W. John, "RFID Technology and Applications", Cambridge University Press, 2008.
- [16] K. Domdouzis, B. Kumar, and C. Anumba, "Radio-Frequency Identification (RFID) applications: A brief introduction," *Adv. Eng. Informatics*, vol. 21, no. 4, pp. 350–355, 2007.
- [17] M. Bukya, A. Bajaj, P. Garg, and A. Saraswat, "Design and implementation of arduino based control system for power management of household utilities," *Intelligent Computing Techniques for Smart Energy Systems*, 2019, Vol. 607, pp 1025- 1031.
- [18] Schwartz M. "Internet of Things with ESP8266," Packt Publishing Ltd, 2016.
- [19] Arduino. (2021, May). Arduino IDE 1.8.15 [Online]Available: <https://www.arduino.cc/en/Main>.

